

## Features:

- The best ESD protection for high frequency, low voltage applications.
- Protects up to 4 separate lines with one device
- Exceeds testing requirements outlined in IEC 61000-4-2
- Extremely low capacitance
- Very low leakage current
- Fast response time
- Bi-directional
- Surface mount
- Solder Termination

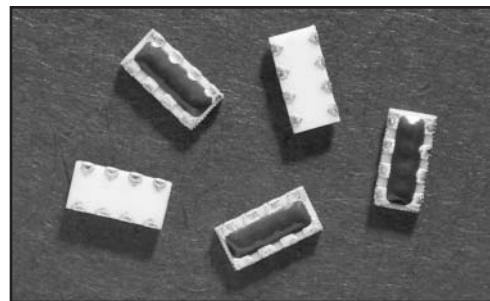

## Description:

The ESDA product family with SurgX® Technology is specifically designed to protect sensitive electronic circuits from the threat of electrostatic discharge (ESD). 4-line array can protect up to 4 isolated lines simultaneously with the same specification as individual chip devices. ESDA devices react almost instantly to the transient voltage and effectively clamp it in an average of 35V for the duration of the ESD transient, meaning less voltage stress during the clamp period and greater IC protection. The design of ESDA series inherently produces an ultra low capacitance part. In the off state the product is virtually invisible to the circuit. Installed from signal line to ground, it is especially transparent to the high-speed digital circuits due

to the high off-state impedance and low capacitance. Signals are not distorted or disrupted as shown by extensive testing. With ESDA series, waveform definition stays true and high-speed signals do not suffer. ESDA series utilize a unique polymer-based material. The nature of the material creates a bi-directional part, which means that only one device is required to provide complete ESD protection regardless of the surge polarity. The combination of this material with proven thick film on ceramic technology produces a reliable, surface mount product that will help protect mobile communications, computers, data processing, test equipment, and many other electronic applications from ESD.

## Part Ratings and Characteristics:

Performance Characteristics	Units	Min	Typ	Max
Continuous operating voltage	VDC	-	12 <sup>1</sup>	-
Clamping voltage <sup>3</sup>	V	-	35	60
Trigger voltage <sup>4</sup>	V		150	300
ESD Threat voltage capability <sup>5</sup>	kV	-	8	15
Capacitance (@ 1 KHz ~ 1.8GHz)	pF	-	0.15	1
Leakage current (@ 12 VDC)	nA	0.01	<0.1	
Peak current <sup>3</sup>	A	-	30	45
Operating temperature	°C	-40	+25	+85
ESD pulse withstand <sup>3</sup>	# pulses	20	>500 <sup>2</sup>	-

### Notes:

1. The product is 100% tested for 30V operating voltage at 25°C. Continuous operation with higher than 12VDC under extreme temperature and humidity may cause increasing leakage current and/or shifting device resistance. However, even under severe environmental test, characteristics of the device did not change up to 12VDC operation.
2. Some shifting in characteristics may occur when tested over several hundred ESD pulses at very rapid rate of 1 pulse per second or faster.
3. Per IEC 61000-4-2, 30A @ 8kV, level 4, clamp measurement made 30 ns after initiation of pulse, all tests in contact discharge mode.
4. Trigger measurement made using Transmission Line Pulse (TLP) method.
5. SurgX devices are capable of withstanding up to a 15 kV, 45A ESD pulse. Device ratings are given at 8kV per Note 1, unless otherwise specified.

## Environmental Specifications:

- Moisture Resistance: MIL-STD-883, Method 1004.7, 85°C, 85%R.H., 240 hrs.
- Thermal shock: MIL-STD-202, Method 107G, -65°C to 125°C, 30 min. cycle, 5 cycles
- Vibration: MIL-STD-202F, Method 201A, (10 to 55 to 10 Hz, 1 min. cycle, 2 hrs each in X-Y-Z)
- Chemical resistance: ASTM D-543, 24 hrs @ 50°C, 3 solutions (H2O, detergent solution, defluxer)
- Full load voltage: Up to 24 VDC, 1000 hrs, 25°C
- Solder leach resistance and terminal adhesion: Per EIA-576
- Solderability: MIL-STD-202, Method 208 (95% coverage)

**Product Dimension**

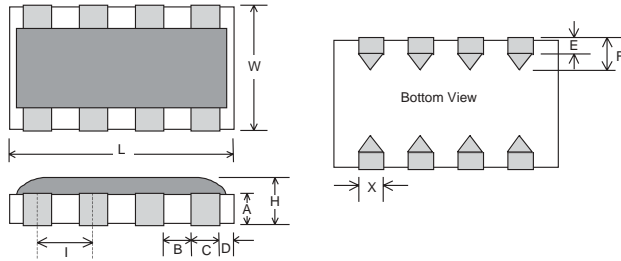

EIA Size	L	W	H	A	B
<b>41206</b>	3.2 ± 0.2	1.6 ± 0.2	0.8 max	0.38 ± 0.5	0.2 min, 0.4 typ
<b>mm(inch)</b>	(.126 ± .008)	(.063 ± .008)	(.032 max)	(.015 ± .002)	(.008 min, .16 Typ)
C	D	E	F	I	X
0.4 Typ	0.2 ± 0.1	0.2 Typ	0.38 ± 0.10	0.80 ± 0.02	0.45 ± 0.02
(.016 Typ)	(.008 ± .004)	(.008 Typ)	(.015 ± .004)	(.03 ± .0008)	(.017 ± .0008)

**Recommended Solder  
Pad Outline  
(per IPC-SM-782)**

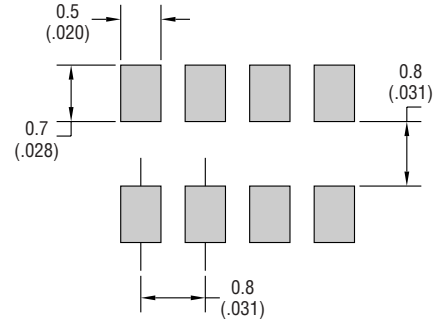

**Tape-and-Reel Specification**

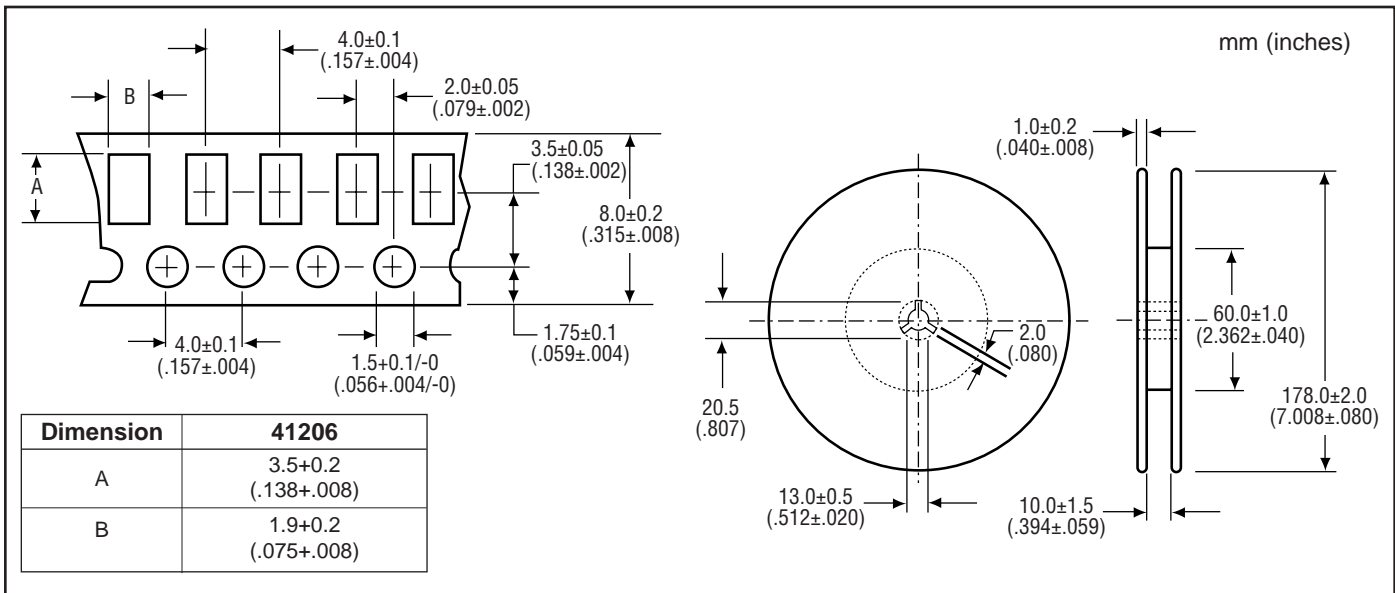

**Part Numbering**

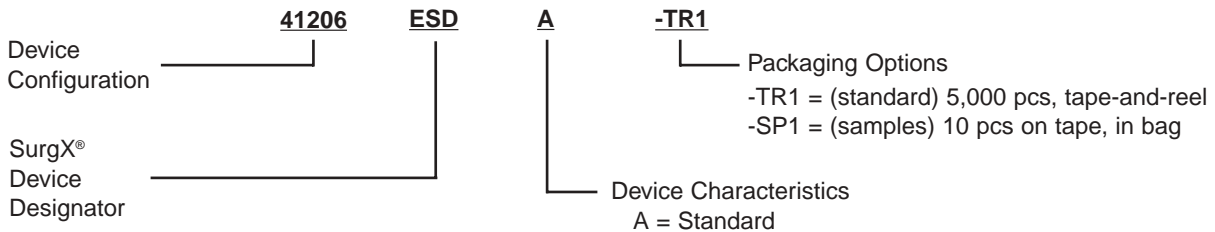

Note: Spacing in part number is shown for clarity only. Device part number contains no spaces (e.g.41206ESDA-TR1)

**Device Marking**

ESDA devices are marked on the tape and reel packages, not individually. Since the product is bi-directional and symmetrical, no orientation marking is required.

**Device Application**

ESDA series are applicable to most signal line circuits. It is applied in a shunt-connected manner. They are not applicable on lines where lightning or load-switching transients are present. ESDA series is ideal for use in computers and computer-related equipment, such as modems, keyboards, and printers. ESDA series is also well suited for portable electronic equipment such as mobile telephones, test equipment, and card scanners.

**Processing Recommendations**

ESDA series currently have a convex profile on the top surface of the part. This profile is a result of the construction of the device. They can be processed using standard pick – and – place equipment. The placement and processing techniques for ESDA series are similar to those used for chip resistors and chip capacitors

The Location in the circuit for the ESDA series has to be carefully determined. For the better performance of the device, it is recommended to place the device close to the signal input, prior to any other component.

**Typical Applications**

